

2008 Toyota FJ Cruiser

SYSTEM WIRING DIAGRAMS

Fig. 14: 4.0L, Engine Performance Circuit (1 of 6)

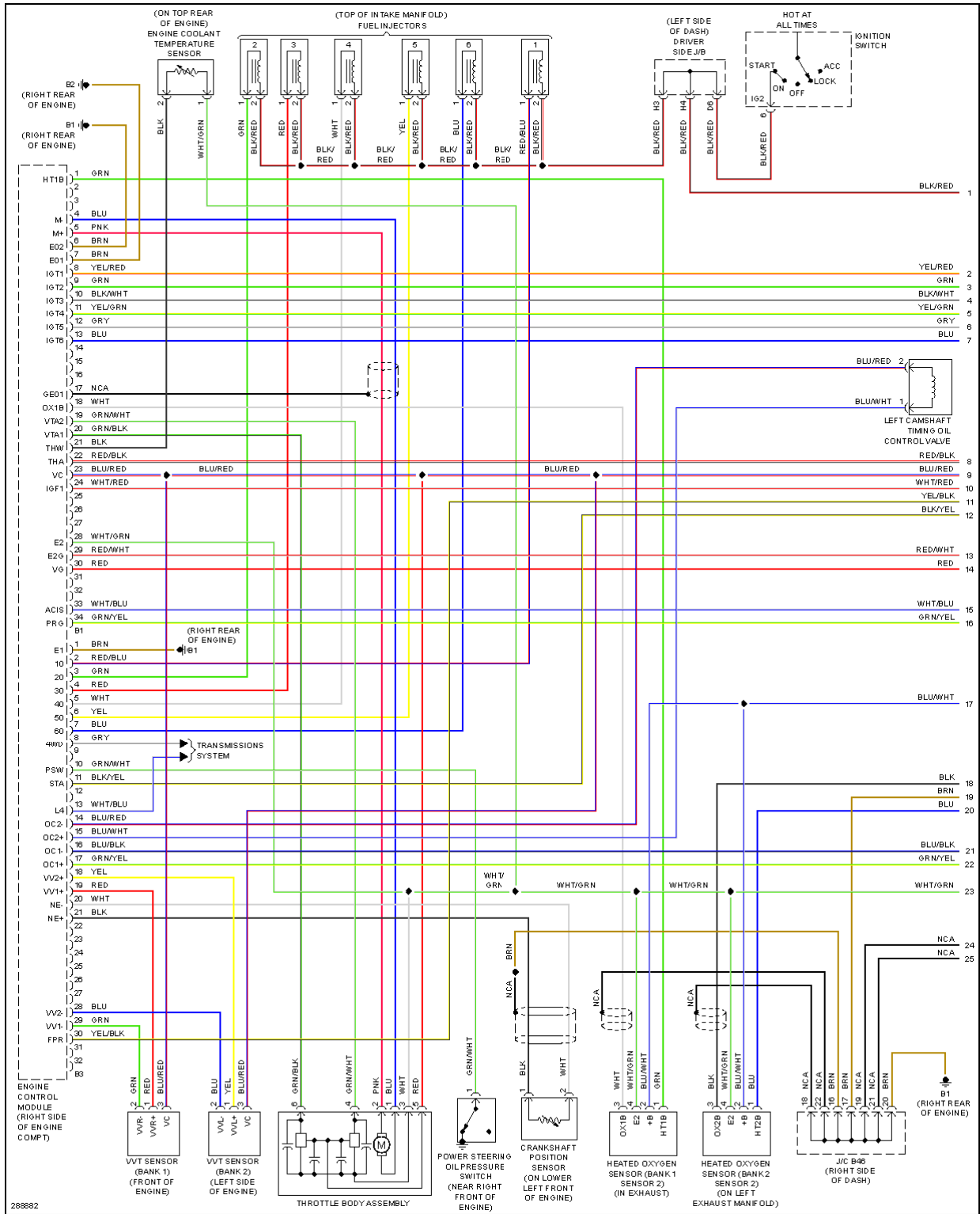

2008 Toyota FJ Cruiser

SYSTEM WIRING DIAGRAMS

Fig. 15: 4.0L, Engine Performance Circuit (2 of 6)

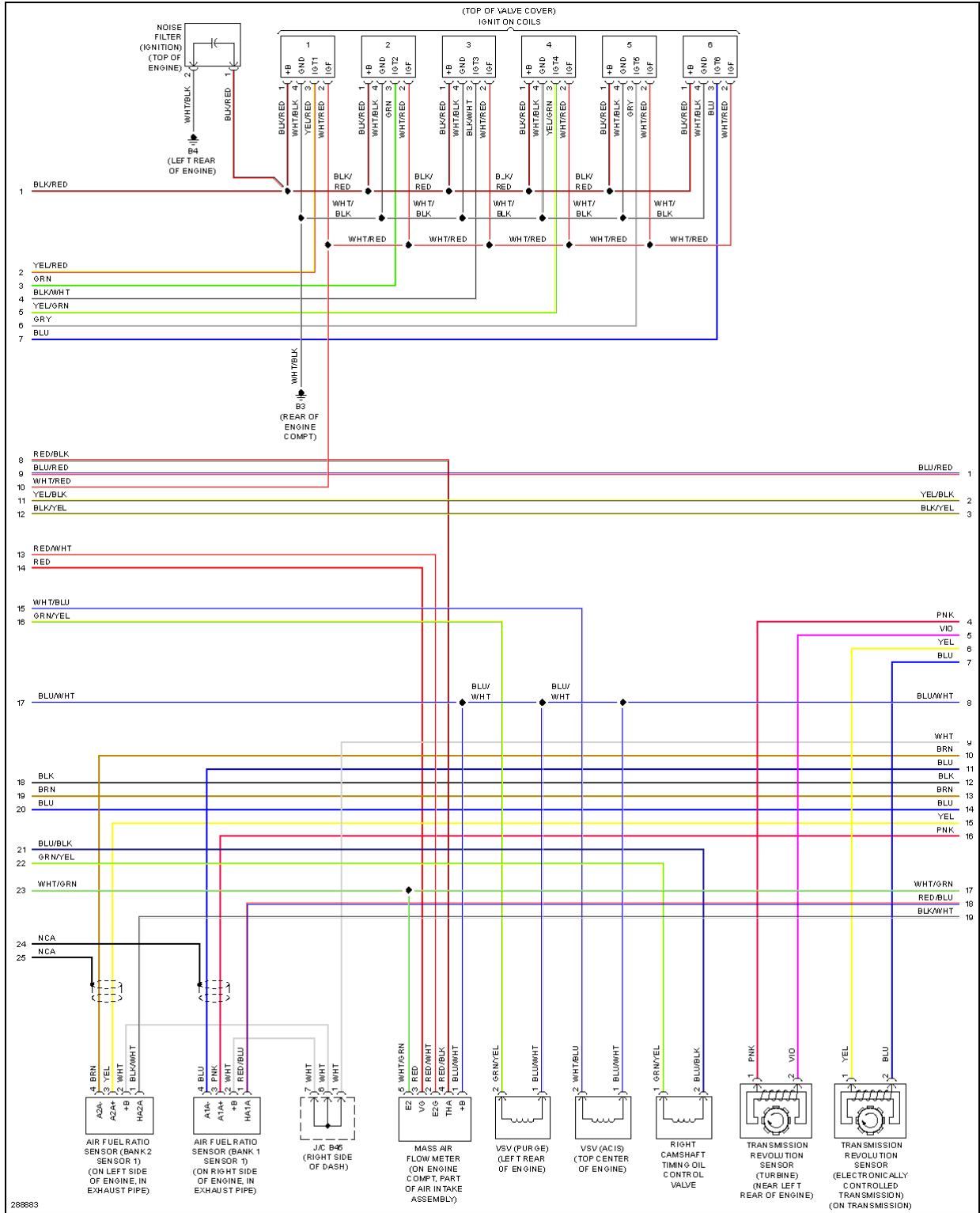

2008 Toyota FJ Cruiser

SYSTEM WIRING DIAGRAMS

Fig. 16: 4.0L, Engine Performance Circuit (3 of 6)

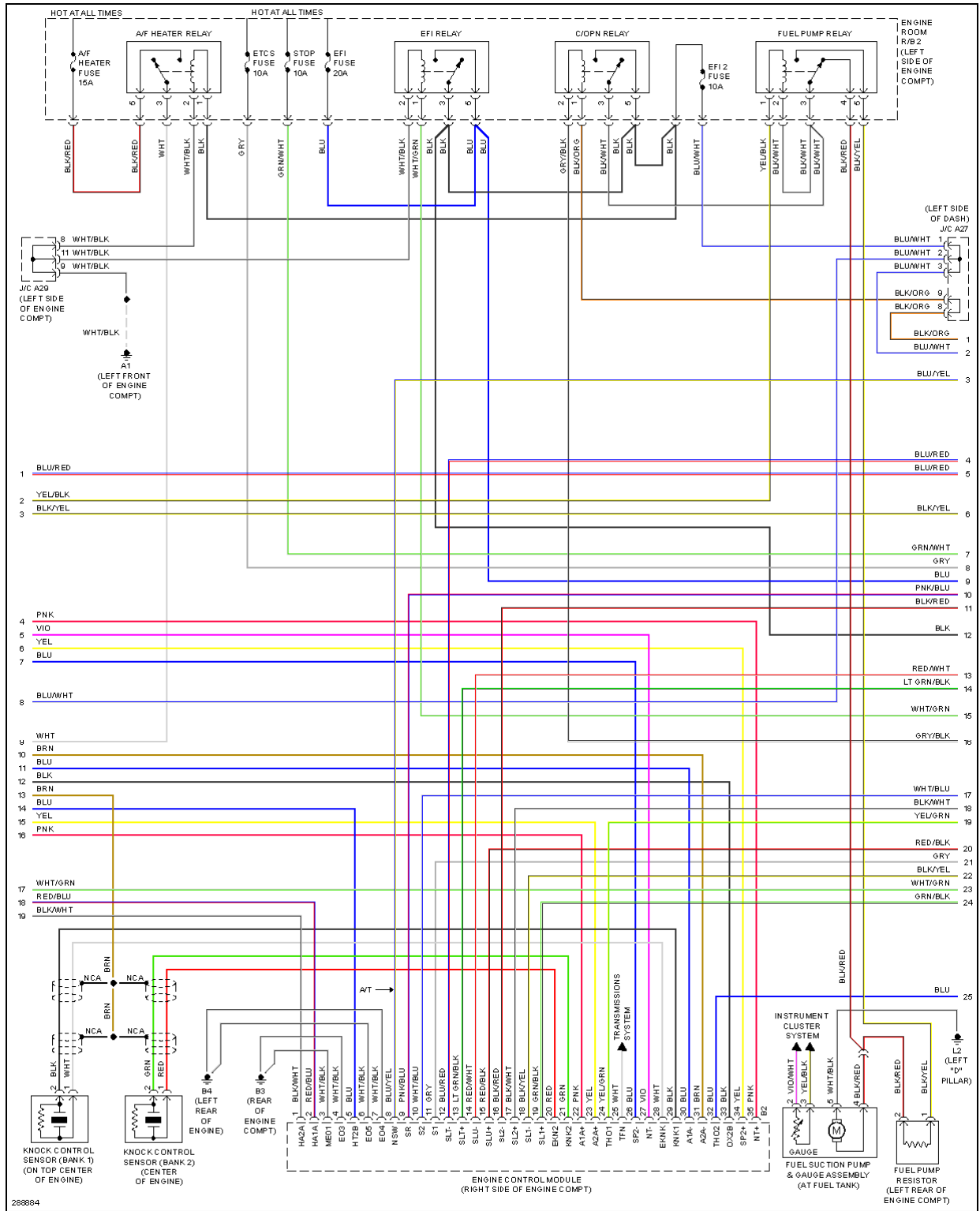

2008 Toyota FJ Cruiser

SYSTEM WIRING DIAGRAMS

Fig. 17: 4.0L, Engine Performance Circuit (4 of 6)

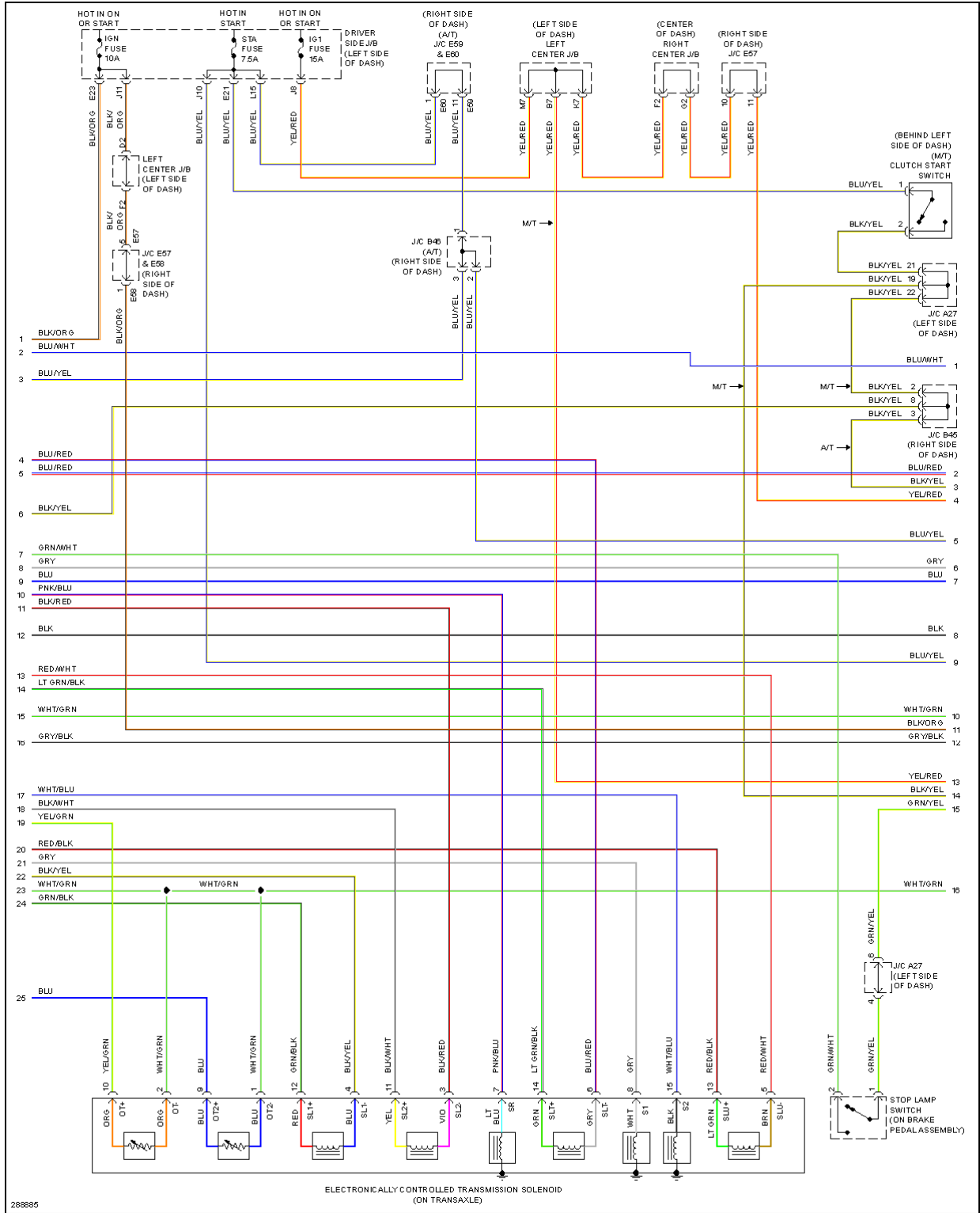

2008 Toyota FJ Cruiser

SYSTEM WIRING DIAGRAMS

Fig. 18: 4.0L, Engine Performance Circuit (5 of 6)

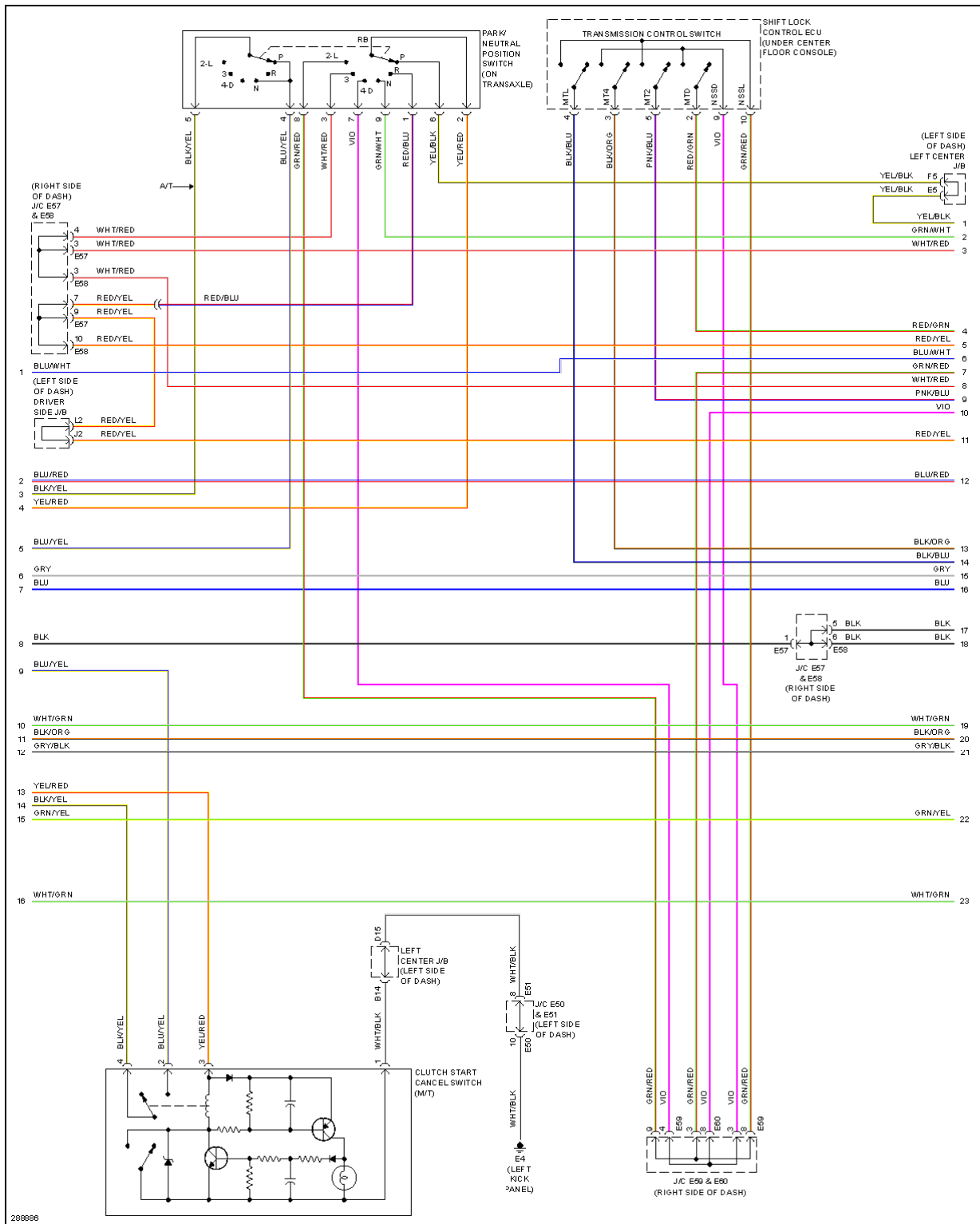

2008 Toyota FJ Cruiser

SYSTEM WIRING DIAGRAMS

Fig. 19: 4.0L, Engine Performance Circuit (6 of 6)

